

Measurement-Based Analysis of Adaptive Relay Selection in Industrial Wireless Sensor Networks

Torsten Andre¹, Nikolaj Marchenko¹, Günther Brandner¹, Wasif Masood¹, and Christian Bettstetter^{1,2}

¹ Institute of Networked and Embedded Systems, University of Klagenfurt, Austria

² Lakeside Labs GmbH, Klagenfurt, Austria

E-Mail: firstname.lastname@aau.at

Abstract—We evaluate by real-world measurements two cooperative relaying protocols for industrial sensor networks: the first one employs a periodic relay selection scheme, where relays are selected periodically from a candidate set at fixed time intervals, while the second one is an adaptive approach selecting relays depending on channel characteristics. We perform measurements of both protocols in a real-world industrial environment, and analyze and compare their performance characteristics in terms of frame delivery ratio and protocol overhead. Results show that the periodic protocol increases the frame delivery ratio considerably compared to direct transmission. Furthermore, the adaptive approach improves frame delivery even further. In particular, for cases where the frame error rate between source and destination is high, adaptive relaying improves frame delivery considerably beyond that of periodic relaying.

Index Terms—Sensor networks, ad hoc networks, cooperative relaying, radio measurements, industrial technology.

I. INTRODUCTION AND MOTIVATION

There are several hundreds of publications on cooperative relaying in wireless systems investigating a broad variety of topics, such as capacity bounds, cooperative channel coding and modulation, medium access protocols, and relay selection protocols. Almost all results are based on mathematical analysis or simulations (see, e.g., references in [1]), but only few performance measurements using implementations in real-world environments were made so far.

The general objective of our research is to close the gap between theoretical and applied research in this area. The paper at hand focuses on a particular aspect of relaying, namely *relay selection*. Common assumptions in theoretical works are either that a cooperative relay is selected only once [2], or relays are selected before every transmission [3], [4]. The first case does not allow to react to changing channel conditions as a selected relay may become unreliable over time, while the second approach may lead to redundant selections in case the same node is selected during consecutive relay selections. In our previous work [5], we determine the impact of various selection intervals by emulation. We extend previous results by analyzing two proactive selection approaches by real-world measurements in an industrial sensor network. To be more specific, we study the concepts of *periodic* and *adaptive* relay selection. Using periodic relay selection, a node is selected to act as relay for a fixed time period. Upon expiration of this period, in general, a new node is selected to become relay. Using adaptive relay selection, a new relay is selected if the

frame error rate (FER) between source and destination exceeds a predefined threshold allowing varying selection intervals. Both approaches reside between the two extremes of selecting a relay only once or every transmission.

Cooperative relaying is interesting for industrial sensor networks [6], as these networks require low-cost devices though highly reliable communication in heavy-cluttered environments. Relaying as applied in this paper requires changes only in the data-link layer allowing cheap development, thus meeting the aforementioned requirements.

The performance of a network of TelosB motes deployed in a factory hall is investigated in terms of

- the *frame delivery ratio* both as a function of source-destination link quality and also averaged over all links,
- the number of *successful relay selections* in relation to the total number of relay selection events and the resulting overhead,
- the *relay selection interval* in which relay selections occur.

The remainder of this paper is organized as follows: Section II gives an overview of related work. Sections III and IV describe the protocols for relay selection and the experiment setup and test execution protocol, respectively. In Section V we evaluate the performance of the relay selection schemes and investigate their influence on system performance. Finally, Section VI concludes the paper.

II. RELATED WORK

A. Related Work on Relay Selection

Many publications propose and analyze relay selection protocols: Bletsas *et al.* [1] propose an algorithm for selecting a relay from a candidate set based on instantaneous channel conditions. The performance of the protocol is evaluated theoretically. Shah *et al.* [3] study several relay selection schemes with respect to time and energy trade-off between selection and data transmission phases. Analytical expressions for throughput and energy consumptions are derived. Fareed *et al.* [7] propose a relay selection method where no feedback information is required at the source node. They derive analytical expressions for symbol error rate and compare the performance of the protocol to other protocols by means of simulations. Adam *et al.* [8] analyze two relay selection schemes with respect to energy efficiency. Specifically, cooperative relaying for industrial wireless networks is also studied

by Willig in [9]. He proposes a simple relaying protocol and analyzes its performance by simulations. Furthermore, many other works are concerned with relay selection protocols and their performance evaluation, e.g. [10]–[12].

B. Related Work on Measurement-Based Analysis of Relaying

The vast majority of publications is based either on analytical or simulative work. Only few real-world measurements are conducted. Petrova *et al.* [13] study the performance of 802.15.4 radio devices for outdoor and office scenarios. The authors of [14]–[16] measure cooperative relaying performance for an individual link, but neglect relay selection.

All of these papers address the performance of the protocols theoretically, by means of simulations or perform measurements of simple relay selection protocols. None, however, assesses the relay selection interval in a network deployed in a real-world environment.

III. RELAY SELECTION PROTOCOLS

The goal of the relay selection protocol is to select a suitable relay to assist a direct communication between source S and destination D . Out of a set of N_P potential relays, i.e. nodes not participating directly in the communication, N_C candidate relays are determined. Candidate relays qualify for relay selection. From a set of candidate relays a node is selected as relay according to its instantaneous channel quality. Relay selection is proactive, i.e. before transmitting a frame the source selects a relay. The periodic and adaptive schemes utilize the same relay selection protocol, they only differ when to initiate a relay selection. In periodic selection, the protocol is executed periodically at fixed intervals L independent of the quality of the selected relay. In comparison, in adaptive selection the protocol is executed based on the quality of the selected relay. Once a cooperative link's FER exceeds a predefined threshold, a new relay selection is initiated, thus leading to variable selection intervals L_a . The protocol is designed to allow reliable evaluation of the performance metrics and to be able to compare the adaptive and periodic relay selection schemes.

Fig. 1 illustrates exemplarily a successful relay selection for a frame transmission between *source* and *destination*, in which a node R_{Sel} is selected successfully as relay, while all other nodes, R_i , step back from the relay selection procedure.

The relay selection protocol is initiated by S in step 1 by broadcasting a relay request frame. Potential relay nodes R_i store the channel quality value Q_{SR_i} of the received relay request and wait for the destination to respond to the relay request (step 2). Having D reply to the request assures that only nodes in the communication range of S and D may be selected. As illustrated in Fig. 2, the destination D is not in the communication range of R_1 , thus R_1 is unsuitable to relay transmissions to D . Assuming reciprocal channels, i.e. if a node A can reach a node B , communication vice versa is generally possible, too, having D send out a request increases the likelihood to find a suitable relay.

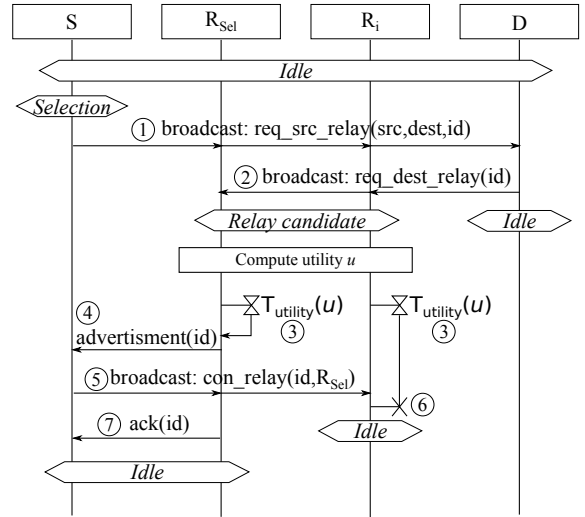

Fig. 1. Relay selection protocol for both selection schemes.

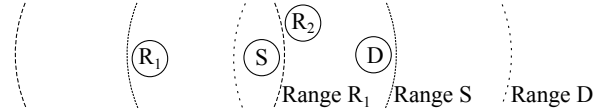

Fig. 2. R_1 is only in the communication range of S and may not communicate with D . To only select relays in communication distance of both S and D , D sends out a relay request.

Nodes having received both relay requests (steps 1 + 2) are called candidate relays and participate in the relay selection by computing their quality values

$$Q_i = \min(Q_{SR_i}, Q_{R_iD}). \quad (1)$$

where Q_{SR_i} and Q_{R_iD} are the quality values of the source and destination requests, respectively, for candidate relay R_i . Other potential relays change their state back to *Idle*. To approximate link qualities the link quality indicator (LQI) is used, which correlates to the FER as shown in [5] (and references therein).

Relay selection is based on timers as suggested in [1]. Each candidate relay R_i starts a backoff timer $T_{b,i}$ based on its quality value Q_i (step 3). The better Q_i , the shorter $T_{b,i}$. This way candidate relays with better quality advertise themselves as in step 4 before candidates with lower quality do. Upon reception S broadcasts a confirmation for the advertising candidate relay confirming its selection. All other candidate relays step back from the selection procedure by stopping their timers (step 6). In the case that several candidate relays send their advertisement before step 5, only the first successfully received advertisement is considered by S . This may lead to redundant advertisements of candidate relays. The advantage of this procedure is to increase the likelihood to finish the selection procedure successfully in case the first advertisement is not received by S .

Finally, in step 7, the selected relay confirms its selection to S which concludes a successful relay selection. The relay selection is only completed successfully if the relay acknowledgment (step 7) is received successfully by S .

IV. EXPERIMENT DESCRIPTION

A. Test Execution Protocol

We deploy a network of devices in which we measure a set of cooperative links with varying source-destination pairs. Fig. 3 illustrates experiment execution of such a single link on the example of a successful cooperative transmission (A) and a successful direct transmission (B). The experiment

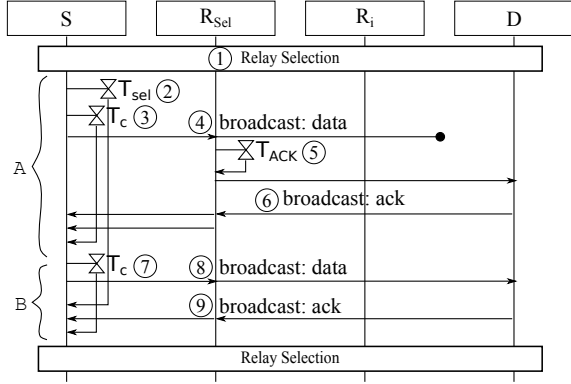

Fig. 3. Test procedure for a source-destination pair.

starts with a relay *selection procedure* (step 1). The relay selection procedure is defined as a maximum of four relay selection attempts. If a selection attempt fails, i.e. no relay could be selected, relay selection is attempted anew until the limit of four attempts is reached. If none of the four attempts is successful, the relay selection procedure fails and the experiment continues without a relay until the next relay selection is triggered.

For periodic selection, relay selections occur in regular intervals of duration T_{Sel} (step 2). In our previous work [5] we determine a suitable interval for regular selection to be $L = 200$ transmission cycles of duration T_c . With $T_c = 120$ ms, T_{Sel} computes to $200 \cdot T_c = 24$ s. We use periodic selection as a configuration baseline for adaptive selection.

In adaptive selection, relay selection occurs after $e_{max} = 5$ failed transmissions. We illustrate the difference of both schemes on the example of a failed relay selection procedure, i.e. no relay was selected. If the direct transmission fails, the cooperative transmission has to fail due to the missing relay. Thus for the adaptive scheme a new relay is selected after five erroneous transmissions. In the periodic case relay selection is triggered periodically leaving the direct link without a cooperative diversity for at least $L = 200$ frames.

Within a transmission cycle, step 4, frames are broadcasted. As depicted, direct transmission to the destination fails while the relay receives the data successfully. Once a relay receives a frame, it starts a timer $T_{ACK} = 30$ ms waiting for an acknowledgment from the destination (step 5). If the relay does not receive an acknowledgment, it forwards the frame to the destination. Finally, in step 6, the destination acknowledges the successful reception by broadcasting an ACK. In case a relay forwards a frame, the relay has to forward the corresponding acknowledgment as well. When the timer T_c

expires a transmission cycle is completed and a new one starts by restarting T_c (step 7). Steps 8 + 9 illustrate a successful direct transmission. The timer T_c is dimensioned to assure non-overlapping transmission cycles.

B. Experiment Setup

Experiments are conducted using off-the-shelf wireless sensor devices—TelosB by Crossbow—in a factory producing packages made of cardboard. Fig. 4 depicts the environment schematically. The sensor nodes are attached in a height of

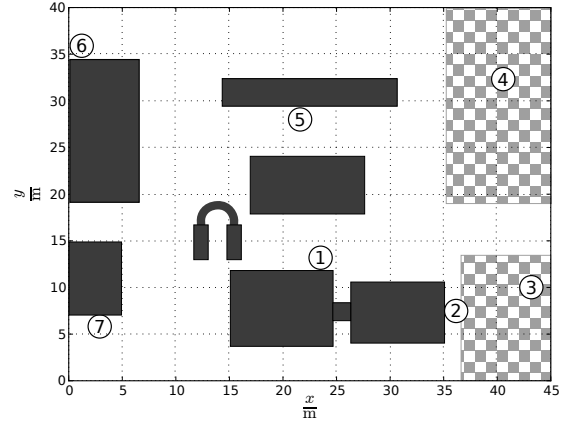

Fig. 4. Factory hall; the dark gray areas are machines with unshielded, moving parts; the checkered areas are storage areas where mostly boxes with cardboard are stored. The numbers indicate the pairwise placements of the sensor nodes.

around 1.8 m at various machines and storage units to act as an industrial wireless sensor network (WSN) with stationary nodes. About a dozen people and several fork lifters move. Additionally the hall includes several machines with unshielded moving parts operated by up to three persons each. The devices are compatible with IEEE 802.15.4, a standard for low-rate, low-energy personal area networks used in industrial standards such as ISA100.11a or WirelessHART. Measurements are done in the 2.4 GHz band. In total, measurements continued for approximately eight hours.

We simultaneously deploy two networks (one for each selection scheme) consisting of $N = 7$ nodes each. One device of each network serves as source and destination each while the remaining $N_P = 5$ devices serve as potential relay nodes. Nodes of both networks are located pairwise next to each other to reduce the effects of spatially correlated fading such as shadowing on a single device to improve comparability between the selection schemes. Experiments are executed simultaneously on distinct frequencies. Source and destination are selected pairwise. Note, however, that relay selection occurs within the distinct networks, hence relay selection does not necessarily occur pairwise. To mitigate (1.) the influence of possible interference from other wireless standards and (2.) frequency selective fading, both selection schemes are run in each of the IEEE 802.15.4 channels 16, 18, 20.

Per link the source transmits up to $N = 5500$ frames with transmission power 0 dBm and frame size 127 bytes to

a predefined destination. Once the source has transmitted all its frames, a new source-destination pair is selected. This way we measured $K = 23$ cooperative links with periodic relay selection, and $K = 27$ with adaptive relay selection.

V. MEASUREMENT RESULTS AND INTERPRETATION

A. Data Analysis

We compute the *direct delivery ratio* p of a direct $S-D$ link and the *total delivery ratio* q for a cooperative link including both the direct link and the diversity transmission path over the relay. For the total delivery ratio, a frame is received successfully if it was received on any of the direct or relay paths. Instead of considering the whole duration of a link¹ to compute p and q , we focus on short intervals of a few seconds by sequencing the data of link $k = 1, \dots, K$ into samples $S_k(j, w)$. Here, $j \in \{1, 2, \dots, N - w + 1\}$ is the index of the sample's starting frame, and w is the sample size in data frames. To obtain a reliable amount of data points, for each cooperative link we slide the sample window through the sequence of frame indices $(1, 2, \dots, N)$ with the step size of one leading to a total of 120 000 samples.

Further we compute tuples (p, q) for all samples $S_k(j, w)$. This allows to collect samples with similar p into $n = 10$ groups with boundaries $0.1(v - 1) \leq x < 0.1 \cdot v, v = 1 \dots n$. For example, all tuples with a value of p between 0.4 and 0.5 are grouped together. Within each such group we then compute the arithmetic mean of all q -values. We confirm the statistical significance of the results by computing the 5% and 95% quantiles of the mean, though omit these values in the figures in favor of the 25% and 75% quantiles (lowest and highest quartiles, respectively) of the data distribution indicating the distribution's spread. The spread allows to compare the consistency for both relay selection schemes, which will be discussed later.

In the presented results the sampling of collected data sequences is done with sample size of $w = 100$ frames. This corresponds to a sample duration of $T_w = 12$ s.

B. Delivery Ratio

Fig. 5 depicts the cumulative distribution function (CDF) of p for all samples $S_k(j, w)$. It illustrates the relative occurring frequency of all samples with $p <$ abscissa. Curves for periodic and adaptive relay selections show slightly different distributions, indicating that underlying direct links have different outage characteristics. In both cases it can be seen that there is a noticeable number of samples with rather high outage probability on direct links ($p < 0.9$). Control or monitoring processes in an industrial wireless sensor network may rely on reliable data delivery, which may not be guaranteed in such samples. We show that cooperative relaying can improve the delivery ratio for such samples significantly.

Fig. 6 visualizes the data distribution in each slice for relaying with periodic and adaptive relay selections. The

¹ $N = 5500$ frames are transmitted in intervals of $T_c = 120$ ms resulting in a total duration of approximately 11 min per link.

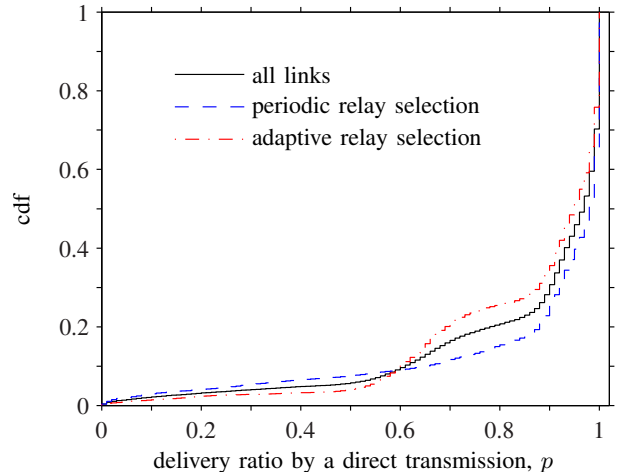

Fig. 5. Cumulative distribution function for the direct delivery ratio. Values are obtained over all links with moving sample window of size $w = 100$ data frames.

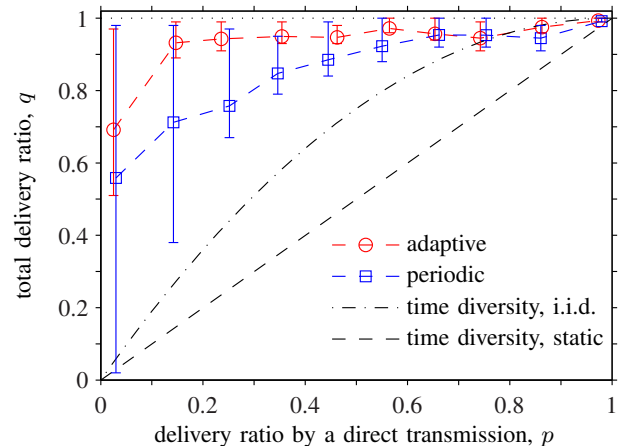

Fig. 6. Schematic distribution of the total delivery ratio within groups and the resulting mean trace. The intervals indicate the 25% and 75% quantiles of the data.

dashed and dot-dashed lines represent the analytically derived total delivery ratio of a time-diversity scheme when a retransmission by S is done after the first transmission fails. The lines correspond to two time-correlation boundaries – quasi-static and independent identically distributed (i.i.d.) channels, respectively. In a quasi-static channel, after a failed first transmission, the retransmission by S is assumed to be also always unsuccessful. Thus, the total delivery ratio for a given sample is equal to p . In an i.i.d. channel, retransmission by S is successful with the same probability p , which results in total delivery ratio $1 - (1 - p)^2$. In real time-correlated channels, the mean values of total delivery ratio for a time-diversity scheme are expected to lie between these two bounds.

The following three main observations can be made from the figure:

1. Both cooperative schemes on average clearly outperform the time-diversity scheme. In samples with $p < 0.7$ the benefits

of cooperative diversity are most evident. The gain compared to time-diversity can be expected to be up to a factor three for adaptive selection and 2.3 for periodic.

2. The mean total delivery ratio decreases with decreasing mean direct delivery ratio. When an $S-D$ channel within a sample has a rather high p , relaying is not triggered often. In a rare case when it is needed, a relay unable to deliver data to D does not have significant impact on the total delivery ratio, and both periodic and adaptive relay selections show similar mean total delivery ratio. When the number of $S-D$ outages in a sample is significant, relaying of data frames plays a crucial role in q . Then, on average, adaptive relay selection provides higher total delivery ratio because relays can be updated more often if the total delivery ratio falls beneath a predefined threshold. In periodic relay selection a relay is not updated until the selection timer expires, even if the total delivery ratio falls below the threshold.

3. The quartile spread on the y -axis for relaying with periodic relay selection increases dramatically with decreasing p . This is due to the presence of relays with very different relaying reliability. If a relay path via a selected relay is very reliable, the achievable total delivery ratio is, independent of p , very high. However, a very unreliable relay path does not improve total delivery ratio significantly. Both cases are likely to occur because the relay is reselected in fixed intervals of $L = 200$ frames, independently of the delivery ratio. At lower p , this decreases the total delivery ratio within the sample and leads to the large quartile spread.

In contrast, in adaptive selection, a relay node is changed when the total delivery ratio drops below a predefined threshold. At low p this leads to a significantly smaller quartile spread, meaning adaptive selection is more reliable and consistent in its performance.

Finally, Table I depicts Fig. 6 in the context of the whole network. For both selection schemes we measured a delivery

TABLE I
DELIVERY RATIOS IN THE NETWORK WITH 5% AND 95% PERCENT QUANTILES OF THE MEAN.

	Periodic			Adaptive		
	5%	Mean	95%	5%	Mean	95%
Direct	0.86	0.86	0.87	0.85	0.86	0.87
Relay path	0.64	0.69	0.77	0.82	0.83	0.85
Total	0.94	0.95	0.96	0.98	0.98	0.98

ratio for the direct transmission of 0.86. Adaptive selection leads to a higher delivery ratio of 0.83 for the relay path, compared to 0.69 in case of periodic selection, thus, improving the total delivery ratio to 0.98 compared to 0.95.

C. Selection Success And Overhead

To analyze the selection overhead we look at relay selection attempts per sample a . In a similar manner as above, the slicing of data points (p, a) over all samples into 10 groups according to their value of p is done and the arithmetic mean of a -values within each group is computed. The resulting schematic distribution in each slice is shown in Fig. 7.

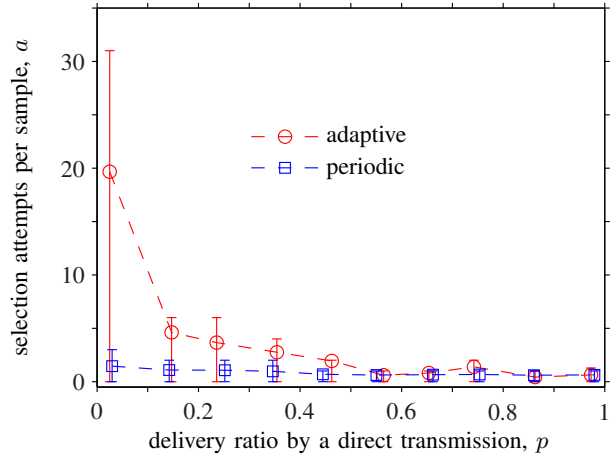

Fig. 7. Schematic distribution of the number of contention attempts (successful and unsuccessful) per sample grouped according to the corresponding direct delivery ratio. The intervals indicate the 25% and 75% quantiles of the data.

Periodic relay selection is triggered in fixed intervals of $L = 200$ frames. Therefore, the mean trace is relatively flat. However, for $p < 0.35$ the mean a increases noticeably. Also the spread of quartiles increases a bit. In such samples, a source may need more selection attempts, since it needs to deliver a signaling message to D over a rather bad $S-D$ channel. Each such attempt is counted here, even if it was not successful.

For adaptive relay selection, there is a clear increase of the mean value and the quartile spread with decreasing direct delivery ratio p . In samples with a bad $S-D$ channel, a relay selection may be triggered multiple times when the total delivery ratio drops below a predefined threshold. In addition, due to bad direct channel, multiple selection attempts may be needed for each triggered selection procedure, which further increases the total number of selection attempts per sample. However, it is also possible that within a sample with low p the relay remains rather reliable and no new relay selections are triggered. The number of selection attempts in such a sample is low. That results in high quartile spread at low p .

Finally, Table II states the selection overhead in the context of the whole network. On average, periodic relay selection

TABLE II
SELECTION OVERHEAD AND RATIO OF SUCCESSFUL SELECTION PROCEDURES IN THE NETWORK WITH 5% AND 95% QUANTILES.

	Periodic			Adaptive		
	5%	Mean	95%	5%	Mean	95%
Attempts/sample	0.68	0.69	0.70	1.08	1.14	1.24
Succ. sel. procedure	0.94	0.95	0.96	0.79	0.84	0.90

requires 40% less selection attempts per sample than adaptive relay selection. This is due to two reasons: i) adaptive selection is triggered more often (6.8 compared to 5 selection procedures per 1000 frames), and ii) adaptive selection attempts are less successful than periodic ones (48% vs. 70%). This

is because adaptive relay selection is always triggered when a cooperative link is in outage. Therefore, successful delivery of a selection request from source to destination is also less probable (see step 1 in Fig. 1). In contrast, periodic relay update might also be triggered when the direct link is not in outage.

D. Selection Interval

Table III shows the overall CDF of the relay update interval L_a with adaptive selection. In around 90% of the cases L_a is

TABLE III
RELAY UPDATE INTERVAL WITH ADAPTIVE RELAY SELECTION

$P(L_a \leq l)$	0.15	0.25	0.50	0.75	0.90	0.92	0.99
l in frames	6	12	24	75	168	215	1381

below the fixed update interval $L = 200$ frames of periodic selection. Note, however, that adaptive selection profits from links with very small FER decreasing the selection interval by up to one magnitude in about 10% of the cases compared to periodic selection.

In 15% of the cases adaptive selection is restarted after six frames indicating that 1. the direct link has a FER of 1.0, 2. either no relay was found after four selection attempts, or 3. a relay was found but transmission failed. This leads to a significant increase in overhead without transmitting frames successfully, depicted in Fig. 7 for $p \leq 0.1$. On the other hand the gain in total delivery ratio q for $p \leq 0.1$ is about 0.15 compared to periodic selection, but still at a comparably low level of $q = 0.7$. This overhead can be decreased by increasing the allowed number of erroneous transmission e_{\max} or by implementing a mechanism which prevents frequent relay selections if the channel's FER temporarily falls below a defined threshold.

VI. CONCLUSIONS

We compared two proactive relay selection schemes, namely periodic and proactive relay selection, by real-world experiments and compared their performance on short periods of a few seconds with different temporary delivery ratios in context of the whole network. We showed that cooperative relaying allows to improve the temporary delivery ratio of the direct link significantly by up to two magnitudes. In context of network we showed an improve in delivery ratio of 11% and 14% for the periodic and adaptive selection scheme, respectively. Further, we conclude that relay selection adapting to a link's FER is beneficial compared to periodic selection, especially in periods with direct delivery ratios smaller than 0.6. The improved reliability comes at costs of increased overhead because, on average, adaptive relay selection is triggered more often than periodic selection with an interval of 200 frames. In cases where the link delivery ratio is below 0.7, both cooperative relaying schemes are expected to outperform the achievable delivery ratio through time diversity by up to a factor of three.

Future work will include comparing various lengths of the periodic selection interval. About 90% of the adaptive selection intervals are below the selection interval of 200 frames. Reducing the periodic selection interval is likely to improve the total delivery ratio at manageable overheads.

ACKNOWLEDGMENT

The authors would like to thank TEWA Verpackungen for providing the measurement environment. This work was performed as part of the project *Cooperative Relaying in Wireless Networks (RELAY)* of the research cluster Lakeside Labs. It was partly funded by the ERDF, KWF, and the state of Austria under grant 20214/15935/23108.

REFERENCES

- [1] A. Bletsas, A. Khisti, D. P. Reed, and A. Lippman, "A simple cooperative diversity method based on network path selection," *IEEE J. Sel. Areas Commun.*, vol. 24, pp. 659–672, 2006.
- [2] E. Zimmermann, P. Herhold, and G. Fettweis, "On the performance of cooperative relaying protocols in wireless networks," *Eur. Trans. Telecommun.*, vol. 16, pp. 5–16, 2005.
- [3] V. Shah, N. Mehta, and R. Yim, "The relay selection and transmission trade-off in cooperative communication systems," *IEEE Trans. Wireless Commun.*, vol. 9, no. 8, pp. 2505–2515, Aug. 2010.
- [4] S. S. Ikki and M. H. Ahmed, "On the performance of cooperative-diversity networks with the n th best-relay selection scheme," *IEEE Trans. Commun.*, vol. 58, Nov. 2010.
- [5] T. Andre, G. Brandner, N. Marchenko, and C. Bettstetter, "Measurement-based analysis of cooperative relaying in an industrial wireless sensor network," in *Proc. IEEE GLOBECOM*, Dec. 2012.
- [6] A. Willig, "Recent and emerging topics in wireless industrial communications: A selection," *IEEE Trans. Ind. Informat.*, vol. 4, no. 2, pp. 102–124, May 2008.
- [7] M. Fareed and M. Uysal, "On relay selection for decode-and-forward relaying," *IEEE Trans. Wireless Commun.*, vol. 8, no. 7, pp. 3341–3346, Jul. 2009.
- [8] H. Adam, C. Bettstetter, and S. Senouci, "Adaptive relay selection in cooperative wireless networks," in *Proc. IEEE Personal, Indoor and Mobile Radio Communications (PIMRC)*, Sep. 2008.
- [9] A. Willig, "How to exploit spatial diversity in wireless industrial networks," *Annual Reviews in Control*, vol. 32, no. 1, pp. 49–57, 2008.
- [10] J. Yindi and H. Jafarkhani, "Single and multiple relay selection schemes and their achievable diversity orders," *IEEE Trans. Wireless Commun.*, vol. 8, no. 3, pp. 1414–1423, Mar. 2009.
- [11] A. Ibrahim, A. Sadek, S. Weifeng, and K. Liu, "Cooperative communications with relay-selection: when to cooperate and whom to cooperate with?" vol. 7, no. 7, pp. 2814–2827, Jul. 2008.
- [12] D. Michalopoulos and G. Karagiannidis, "Performance analysis of single relay selection in Rayleigh fading," *IEEE Trans. Wireless Commun.*, vol. 7, no. 10, pp. 3718–3724, Oct. 2008.
- [13] M. Petrova, J. Riihijarvi, P. Mahonen, and S. LaBell, "Performance study of IEEE 802.15.4 using measurements and simulations," in *Proc. IEEE Wireless Commun. and Netw. Conf. (WCNC)*, Apr. 2006, pp. 487–492.
- [14] P. Kyritsi, P. Eggers, R. Gall, and J. M. Lourenco, "Measurement based investigation of cooperative relaying," in *Proc. IEEE Vehicular Technology Conf. (VTC-Fall)*, Sept. 2006.
- [15] G. Bradford and J. Laneman, "An experimental framework for the evaluation of cooperative diversity," in *Proc. Conf. on Information Sciences and Systems (CISS)*, Mar. 2009, pp. 641–645.
- [16] S. Valentin, H. Lichte, D. Warneke, T. Biermann, R. Funke, and H. Karl, "Mobile cooperative WLANs - MAC and transceiver design, prototyping, and field measurements," in *Proc. IEEE Vehicular Technology Conf. (VTC-Fall)*, Sep. 2008.